

## External Clock Sync Function

Connecting the N-05 to an external G-02 Master Clock Generator allows more accurate synchronization between internal digital circuits, thereby enabling significant improvements in system sound quality. The N-05 is compatible with 44.1/88.2/176.4kHz word clocks as well as both 10MHz and 22MHz direct master clock LINK.\*



\*The clock generator's master clock signal is used 'as is' by the D/A converter, bypassing its internal PLL circuit to allow straighter, more high-accuracy D/A conversion.

## Versatile D/D Converter

The N-05 is equipped with a highly versatile D/D converter and digital filter. In addition to playback at the original sampling frequency, 2x, 4x and 8x up-conversion of the PCM digital signal, as well as cross-format conversion of PCM and DSD using a proprietary algorithm, are all freely selectable. Digital filtering (of both PCM and DSD) can also be enabled or disabled as desired.

## A Multitude of Digital Inputs

The N-05's array of digital inputs include USB (x1), coaxial (x1) & optical (x1). The coaxial and optical inputs are compatible with both 192kHz/24-bit PCM and 2.8MHz DSD (DoP), while the USB port supports asynchronous transmission and native playback of 2.8/5.6/11.2MHz DSD and 384kHz/32-bit PCM.

## Complete Noise Isolation

The analog circuit following the N-05's D/A converter is separated from its digital circuitry by an isolator that ensures complete noise reduction to maintain the purity of the analog sound output.

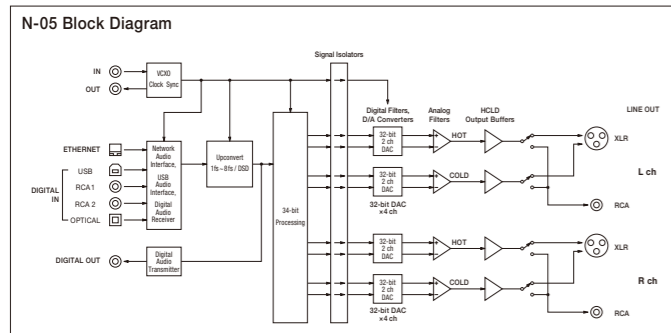

## Specifications

<b>Digital Audio Inputs</b>	
RCA Connectors	2 pairs (L/R)
Input Level	0.5Vp-p
Input Impedance	75Ω
Input Signal Formats	32 - 192kHz 16 - 24-bit Linear PCM (IEC 60958) DSD (DoP)
Optical Digital Connector	1
Input Level	-24.0 to -14.5dBm (peak)
Input Signal Formats	32 - 192kHz 16 - 24-bit Linear PCM (IEC 60958) DSD (DoP)
USB Port	1 (Type B)
Input Signal Formats	44.1 - 384kHz 16 - 32-bit Linear PCM 2.8/5.6/11.2MHz DSD
Ethernet Port	1000BASE-T
Input Signal Formats	44.1 - 384kHz 16 - 32-bit Linear PCM 2.8/5.6MHz DSD
<b>Supported File Formats</b>	
DSD Lossless	DSF, DSDIFF (DFF), DoP
PCM Lossless	FLAC, Apple Lossless (ALAC), WAV, AIFF
Compressed Audio	MP3, AAC (m4a container)
USB Storage Device Port	.FAT32; USB 2.0 or faster recommended
<b>Digital Audio Output</b>	
RCA Connectors	1
Output Level	0.5Vp-p (into 75Ω load)
Output Impedance	75Ω
Output Signal Formats	44.1 - 192kHz 16 - 24-bit Linear PCM (IEC 60958 format) DSD (DoP format)

<b>Clock Sync Input</b>	
BNC Connectors	1
Input Frequencies (±15 ppm)	44.1, 48, 88.2, 96, 176.4, 192kHz 10, 22.5792, 24.576MHz
Input Impedance	75Ω
Input Level	Rectangle wave: TTL level equivalent Sine wave: 0.5 to 1.0Vrms (50 - 75Ω)

<b>Clock Sync Output</b>	
BNC Connectors	1
Output Level	TTL level equivalent (into 75Ω)
Output Frequencies	44.1, 88.2, 176.4, 48, 96, 192kHz 22.5792, 24.576MHz Equivalent to input frequency (at through output)

<b>Analog Audio Outputs</b>	
XLR Connectors	1 pair (L/R)
RCA Connectors	1 pair (L/R)
Output Impedance	XLR: 20Ω RCA: 20Ω
Maximum Output Level (at 1kHz, 10kΩ load)	XLR: 5.0Vrms RCA: 2.5Vrms
Frequency Response (192kHz PCM)	5Hz - 70kHz (-3dB)
S/N Ratio	117dB
Distortion	0.0007% (1 kHz)
<b>General</b>	
AC Power Supply	230V, 50Hz / 120V, 60Hz / 220V, 60Hz
Power Consumption	18W
External Dimensions (W x H x D, including protrusions)	445 x 107 x 356mm (17 5/8 x 4 1/4 x 14 1/8")
Weight	11kg (24 3/8 lb)

### Included Accessories

- Power cord x 1
- Owner's manual x 1
- Warranty card x 1

PROUDLY MADE IN TOKYO

# ESOTERIC

ESOTERIC COMPANY

1-47 Ochiai, Tama-shi, Tokyo 206-8530, Japan  
Fax: (042) 356-9240  
www.esoteric.jp

Please note that Esoteric products are only available at select distributors in respective countries.  
\*Esoteric and "Grandioso" are trademarks of TEAC Corporation, registered in the U.S. and other countries.  
©2016 TEAC Corporation. All Rights Reserved. All text, images, graphics and other materials in this catalogue are subject to the copyright and other intellectual property rights of TEAC Corporation. These materials shall not directly or indirectly be published, reproduced, modified or distributed in any medium.  
\*Super Audio CD™ and "DSD" are registered trademarks. IOS is a trademark or registered trademark of Cisco in the U.S. and other countries and is used under license.  
Apple, iPhone and iPad are trademarks of Apple Inc., registered in the U.S. and other countries. Android is a trademark of Google Inc.  
Other company names and product names in this document are the trademarks or registered trademarks of their respective owners.  
Design and specifications are subject to change without notice.



PRINTED IN JAPAN 0416005 • TECD-0225



# To the Future of Musical Reproduction

Total sound quality without compromise.

This has been Esoteric's core philosophy since its birth in 1987.

Now this zeal for excellence extends to the highest quality in music streaming, pushing Esoteric to develop a new network audio player — one that offers listeners supreme ease in their musical enjoyment.

From DSD high-resolution masters to reacquaintances with old classics lying hidden for years in a corner of your CD library, all can be instantly accessed from your giant music library, and all from the comfort of your listening seat.

Passion and pride invested in advanced technology and exquisite craftsmanship support high quality you can rely on.

Let the N-05 bring you closer still to the music you love, and lead you to a more complete sense of musical enjoyment.

Onward to the future of musical reproduction.



## Network Audio

Access any music you like and play it back with the finest in sound quality, all without moving from the comfort of your listening seat — the N-05 makes this luxurious dream a reality. Enjoy the vivid musical experience of DSD master sound sources. Convert giant CD collections to a digital library for quick and easy access. Actively seek out new encounters in music with TIDAL. Use your home network environment to make your relationship with music ever closer.

Besides your home audio components, all you need are a standard domestic LAN connection (w/ wireless router) and an iPad. A large-capacity NAS\* device can hold your entire music library. With these few items, a comfortable life of high-quality musical enjoyment without compromise can soon be yours.

\*NAS: Network Attached Storage. Recommended server software: MinimServer. Updated information regarding NAS compatibility can be found on our home page.

## Compatible With a Variety of Audio Sources

A thorough infusion of select high-end specifications ensures the N-05 delivers superb sound quality. Compatible with 2.8/5.6MHz DSD, 192kHz/24-bit PCM and a host of other formats (DSF, DSDIFF, FLAC, Apple Lossless, WAV, AIFF, MP3, and AAC),\* gapless playback capability is also offered in all lossless formats, permitting full enjoyment of live or opera recordings with no interruptions between musical tracks.

\*384kHz/24-bit PCM native playback in USB DAC mode and down-converted playback in network mode also provided.

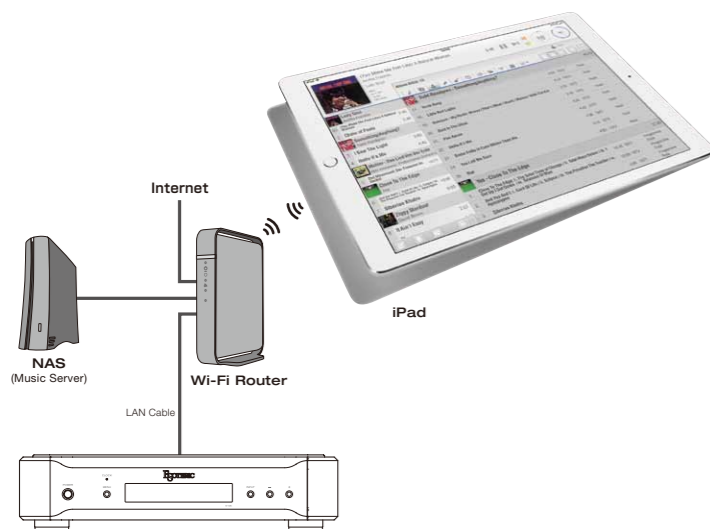

PROUDLY MADE IN TOKYO  
**ESOTERIC**

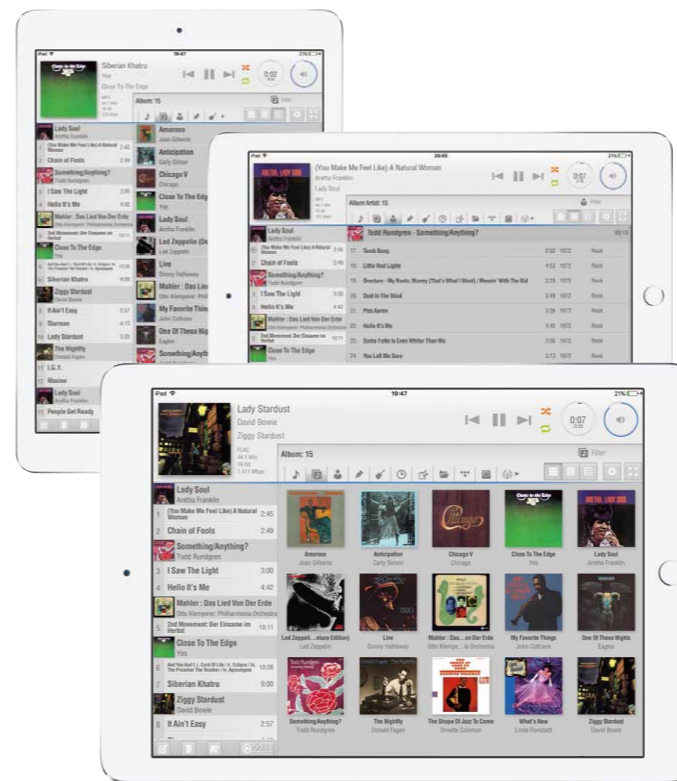

## Esoteric Sound Stream

Esoteric Sound Stream is an Apple iOS application for the iPad\* designed with an emphasis on both sound quality and network playback operating ease. Its basic operation simply entails selecting musical tracks using the iPad, creating customized personal playlists, and playing the selections or playlists. All screens for key operation, playlists, library, etc. are arranged for easy viewing, enabling even users unfamiliar with the app to operate it with intuitive ease. Its high degree of refinement even meets the rigorous demands of advanced and experienced users.

Key to this achievement is the app's excellent search and retrieval performance, which takes full advantage of tag information. Since images are also cached in the app, album artwork can be instantly scrolled through and libraries can be freely sorted into such classifications as artist, year of recording, composer or category. This use of tag information even allows musical numbers of the same name which differ in format to be easily identified on the screen.

\*Apps for use with iPhone and Android also currently under development.

## Music Server Function

The N-05 can also be used as a simplified music server integrating both player and library by connecting a large-capacity storage device to the USB port on its rear panel. With the ability to be used as a secondary music server, even users new to the NAS directory structure can easily get started.



## ESOTERIC x TIDAL\*

Begin your encounters with new music through TIDAL, a high-end music streaming service that has officially partnered with Esoteric. TIDAL's lossless music distribution service operates on a fixed rate basis. Offering instant access to its enormous sound library, TIDAL enables users to enjoy their favorite music online with excellent sound quality.

\*Available only in limited locations, TIDAL cannot be used in areas where the service is not provided.

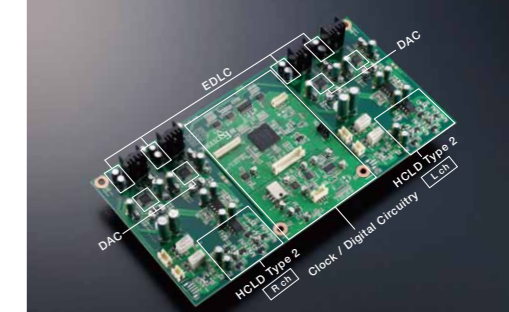
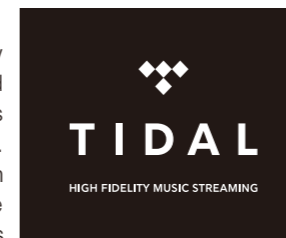

## Dual Mono D/A Converters

A feature of its Super Audio CD players, Esoteric's D/A converters and analog circuitry have won accolades for total sound quality. Employing Asahi Kasei Microdevices' AK4490 chip set, the converter is configured in four parallel and differential circuits (8 outputs) driving each channel to achieve superb sound quality with remarkable linearity and low distortion. Its discreet dual mono configuration also provides excellent channel separation.

Technology developed for the Grandioso C1 is also employed in the DAC's power supply, which features EDLC\* super capacitors. This regulated power supply boasts a total capacity of 500,000 $\mu$ F per channel for exceptional low-frequency sound reproduction.

\*EDLC = Electronic Double-Layer Capacitors

## 34-Bit D/A Processing

The N-05 uses a 34-bit D/A processing algorithm to convert the high-resolution 34-bit PCM signal to analog. This 34-bit encoding resolution is an astounding 1,024 times more detailed than that of 24-bit encoding. In the digital range, full advantage is also taken of this processor's high-bit data gradation to minimize calculation errors and provide faithful analog conversion for outstanding and highly sensitive powers of expression.

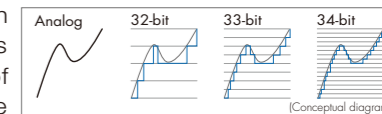

## Esoteric-HCLD\* Type 2 Buffer Amplifier

The N-05's Esoteric-HCLD Type 2 buffer amplifier was developed with know-how derived from such high-end models as the Grandioso C1 preamplifier, and boasts excellent direct current transmission capability, as well as a powerful drive output. Two of these buffer amplifier circuits are installed per channel and configured differentially to drive the XLR outputs, and in parallel to drive the RCA outputs. The strong drive provided to connected equipment ensures that the source's full dynamic range is recreated with a breathtaking sense of realism.

\*HCLD = High Current Line Drive

## Robust Power Supply

A robust power supply is critical to the accurate reproduction of all the vibrant energy of music. The N-05 is equipped with a high-output power supply circuit that integrates an enormous, custom-designed toroidal transformer and an array of large capacitors to provide clean and steady power to each circuit block.



## High-Precision VCXO Clock

A high-precision VCXO (voltage controlled crystal oscillator) supplies a highly accurate reference clock signal to the digital circuitry. The N-05's large, custom-designed VCXO was jointly developed with Nihon Dempa Kogyo (NDK), a leading manufacturer of crystal oscillators, exclusively for high-quality audio playback. The cornerstone of quality sound, its large crystal element realizes both excellent center accuracy ( $\pm 0.5$ ppm, as shipped from the factory) and extremely low levels of phase noise to ensure exceptional sound playback quality.

